

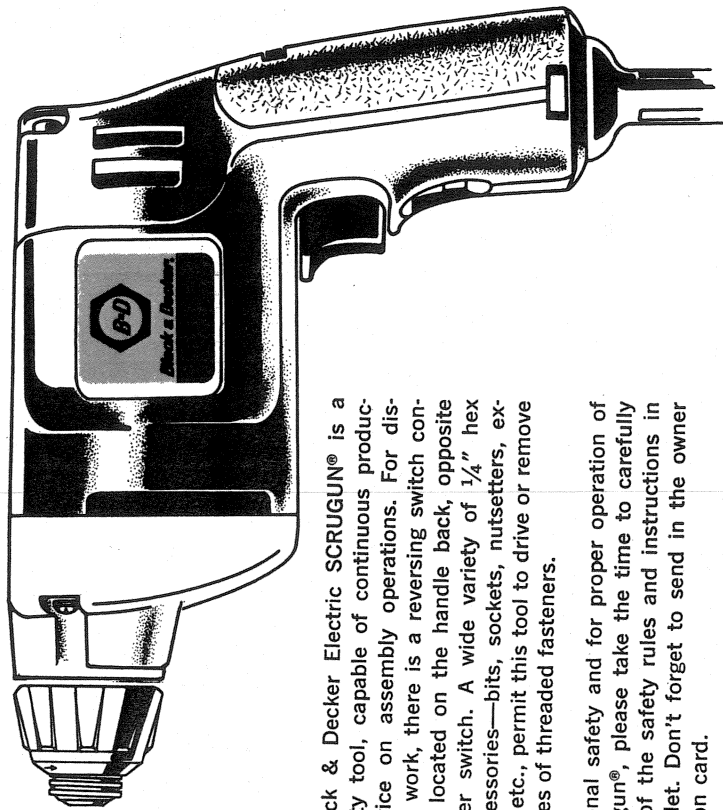

OWNER'S MANUAL



Your Black & Decker Electric SCRUGUN® is a heavy-duty tool, capable of continuous production service on assembly operations. For disassembly work, there is a reversing switch conveniently located on the handle back, opposite the trigger switch. A wide variety of 1/4" hex drive accessories—bits, sockets, nutsetters, extensions, etc., permit this tool to drive or remove many types of threaded fasteners.

For personal safety and for proper operation of the Scrugun®, please take the time to carefully read all of the safety rules and instructions in this booklet. Don't forget to send in the owner registration card.

THANK YOU for buying BLACK & DECKER!

• DOUBLE INSULATED •
HEAVY-DUTY

SCRUGUN® SCREWDRIVERS

Cat. Nos.

- 2020-10 POSITIVE CLUTCH
- 2025-10 VERSA-CLUTCH®
- 2033-10 DRYWALL
- 2034-10 DRYWALL
- 2022-10 POSITIVE CLUTCH
- 2032-10 DRYWALL
- 2034-15 DRYWALL

IMPORTANT

To assure product SAFETY and RELIABILITY, repairs, maintenance and adjustment, (including brush inspection and replacement) should be performed by Black & Decker Service Centers or other qualified service organizations, always using Black & Decker replacement parts.

COMMERCIAL/INDUSTRIAL USE WARRANTY

Black & Decker warrants this product for one year from date of purchase. We will repair without charge, any defects due to faulty material or workmanship. Please return the complete unit, transportation prepaid, to any Black & Decker Service Center or Authorized Service Station listed under "Tools Electric" in the yellow pages. This warranty does not apply to accessories or damage caused where repairs have been made or attempted by others.

BLACK & DECKER (U.S.) INC.,
626 Hanover Pike, Hampstead, Maryland 21074

Form No. 740228-02

(APR83-CD)

Printed in U.S.A.

ACCESSORY ASSEMBLY & ADJUSTMENTS

The 1/4" HEX DRIVE QUICK CHANGE CHUCK (Fig. 3) is used on all positive and versa-clutch units. A ball retainer provides positive locking of all accessories in the chuck. Push forward on the ball retainer and hold while inserting or removing accessories. Release for positive accessory retention.

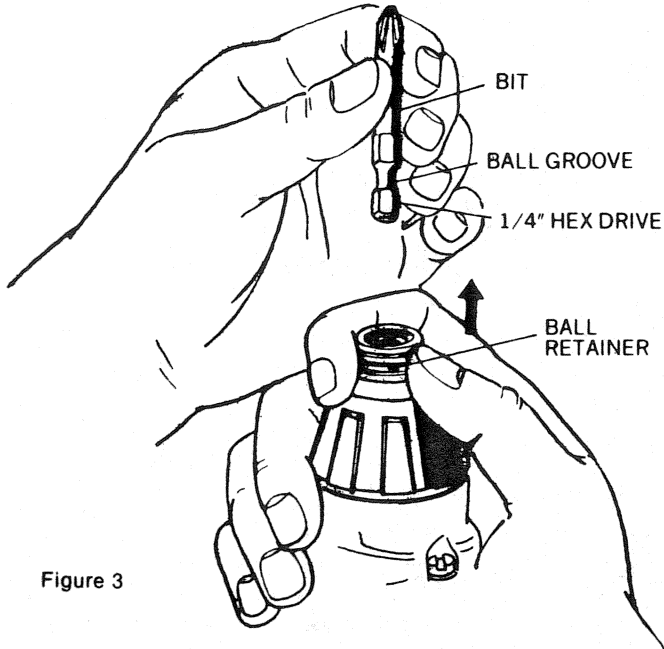

Figure 3

ACCESSORY ASSEMBLY & ADJUSTMENT FOR DRYWALL UNITS (Fig. 4)

The 1/4" HEX DRIVE BALL LOCK CHUCK is used on all drywall screwdrivers.

To change Bit Holders on Drywall Units

1. Unscrew collar AND locator assembly from gear case (left hand thread).
NOTE: There is no need to unscrew locator from collar.
2. Pull bit holder straight out with pliers, if it is difficult to remove.
3. Push new bit holder into spindle until ball lock snaps in groove in bit holder shank.
4. Replace collar and locator assembly.

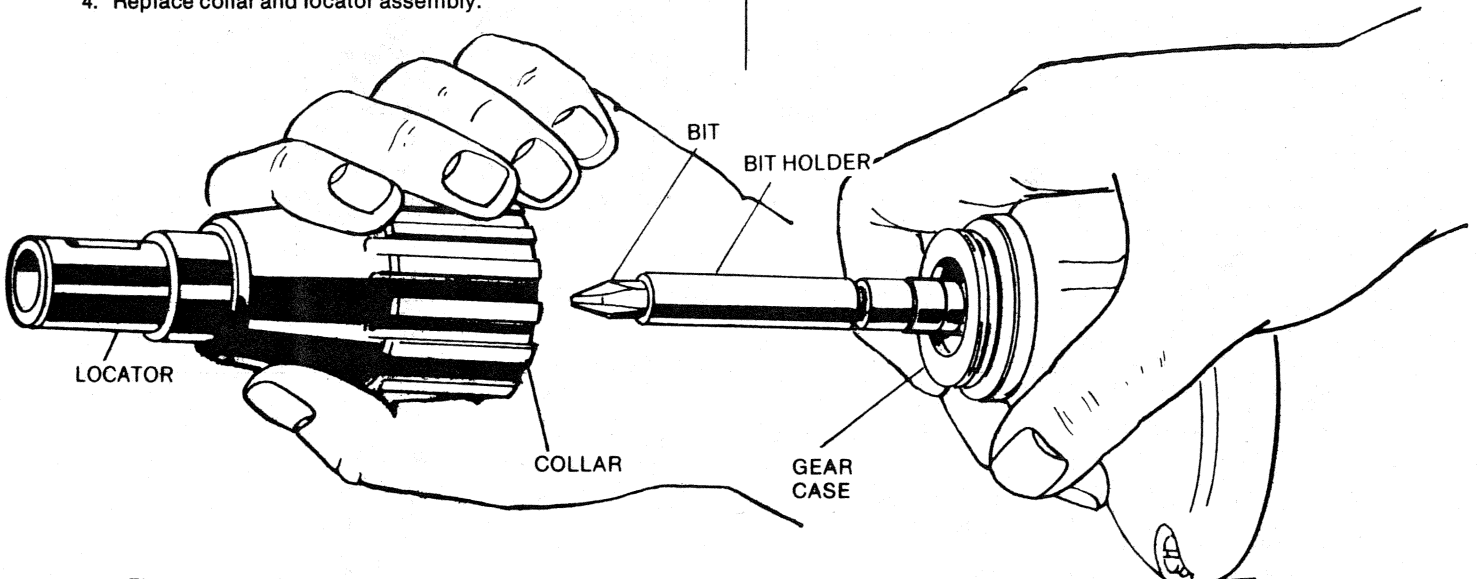

Figure 4

DEPTH ADJUSTMENT ON DRYWALL UNITS (Fig. 5)

1. Turn locator until end of bit extends 3/16" beyond end of locator.
2. Test drive a fastener in scrap material to determine if fastener is correctly seating.
3. Further adjustment may be necessary to increase or decrease the fastener depth.

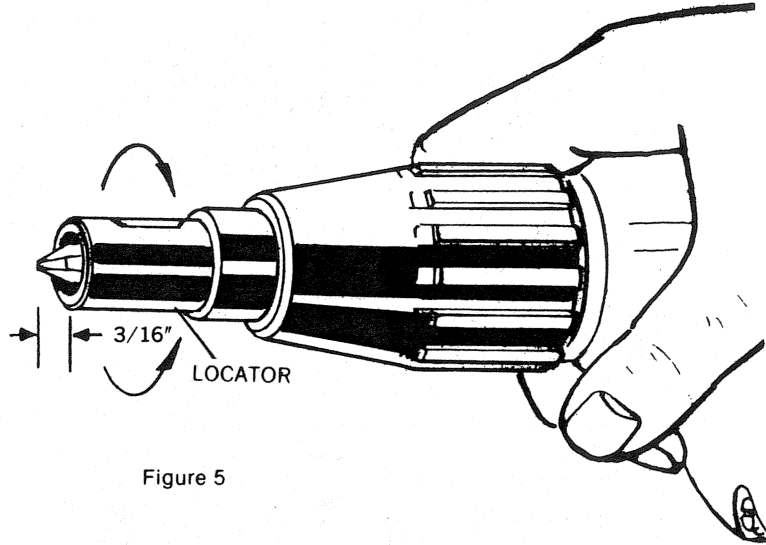

Figure 5

TO INCREASE, turn the locator so that end of bit extends further from end of locator.

TO DECREASE, turn the locator so that end of bit is closer to end of locator.

Black & Decker Drywall Units have very fine depth settings, each "detent" is .0052" or one revolution of the locator equals .083" change in depth setting.

SCREWDRIVER ACCESSORIES continued

Hex Drive Shank Extensions



	SHANK SIZE	SQ. DR.	LENGTH
	1/4**	1/4"	2"
*For use with 1/4" square drive sockets—1/4" hex.	1/4**	1/4"	6"

Sockets for the above:

FOR DRIVING
HEX NUTS AND
SHEET METAL
SCREWS



1/4" Sq. Drive

	TYPE	SOCKET SIZE	DIAM.	LENGTH
Non-Magnetic		1/4"	1/2"	7/8"
		5/16"	1/2"	7/8"
Magnetic		3/8"	9/16"	15/16"
		1/4"	7/16"	7/8"
		5/16"	1/2"	7/8"
		3/8"	9/16"	7/8"

SCREW TYPE AND NUMBER SIZE

FLAT OR OVAL	ROUND	FILLISTER	BINDING	PAN	TRUSS

1/4" Hex Bits For Slotted Head Screws

3,4	3,4	4,5	3	4	2
5	5	6	4	5	3,4
6	6	8	5	6	—
8	8	10	6,8	8	5,6
10	10,12	12	10	10	8
12,14,1/4	14,16,1/4	1/4	12,1/4	12,1/4	10
12	14,1/4	1/4	12	12	10

1/4" Hex Bits With Rotating Finder For Use With Any 1/4" Hex Drive

Power Tool 

						BIT LENGTH
4,5	4,5	4,5,6	4,5	4,5	—	3-1/2"
8	8	8,10	6	8	5,6	3-1/2"
8	8	8,10	6	8	5,6	6"
10	10	12	8,10	10	8,10	3-1/2"
12	12	1/4	—	12	—	3-1/2"

MISC. SCREWDRIVER ACCESSORIES

6" Hex Bit Extension
For use with 1/4" Hex Shanks and/or other extensions.

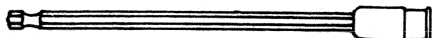

1/4" Square Drive Magnetic Socket
For driving 8 Pointed Nylon and Steel Headed Screws.



Heavy-Duty Tool Box
Cat. No. 50078

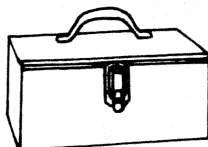

Scrugun® Holster Cat. No. 69590
attaches to belts up to 2-3/4" wide.



Magnetic Bit Tip Holders
for Drywall Scruguns

1/4" Hex Shank for 1/4" Hex Tip (3-3/32 long) for use with all Drywall SCRUGUNS® EXTRA LENGTH BIT TIP DRIVE BODY.

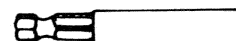

1/4" Hex Shank for 1/4" Hex Tip (2-31/32 long) for use with all Drywall SCRUGUNS® STANDARD LENGTH STAINLESS STEEL BODY. (Standard equipment on H.D. drywall SCRUGUNS®)

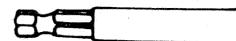

BELT CLIP Cat. No. 69600
For all H.D. SCRUGUN Screwdrivers.
(Standard equipment on H.D. drywall SCRUGUNS®)

VERSA-CLUTCH FOR DRIVING A WIDE RANGE OF FASTENERS

RPM	NOMINAL CAPACITY					
	WOOD SCREWS	LAG SCREWS	SELF DRILL SCREWS	THREAD CUTTING SCREWS	SHEET METAL SCREWS	MACHINE SCREWS
0-1200	#12	1/4" w/pilot hole	1/4" 3/16" CRS	1/4"	1/4"	1/4"

1. Install proper fastener driving accessory and set screwdriver for correct rotation.
2. Adjust clutch setting. See Fig. 4.
3. Place fastener in accessory, contact workpiece and apply pressure to seat fastener keeping clutches engaged.
4. Upon fastener seating the clutches will ratchet. Disengage screwdriver from fastener.

NOTE: With Versa-Clutch the operator has the ability to "override" clutch ratchet if a fastener hits a wood knot, variable hardness in steel workpieces or incorrect pilot holes. Increased operator pressure will usually cause the clutches to "pick-up" and continue to seat the fastener. Further, a quick twist of the collar will change the clutch setting to overcome most driving difficulties and will provide for immediate change in torque output giving the operator option to drive a range of fastener sizes.

MAINTENANCE

CLEANING

With the motor running, blow dirt and dust out of all air vents with dry air at least once a week. Wear safety glasses when performing this.

Exterior plastic parts may be cleaned with a damp cloth and mild detergent. Although these parts are highly solvent resistant, NEVER use solvents.

CHANGING CLUTCHES (Fig. 7) FOR VERSA-CLUTCH ONLY

1. Remove clutch housing by unscrewing in direction of arrow (left hand thread).
2. Clamp tool or clutch housing in a resilient clamp.
3. Remove round clutch retaining rings with a very small screwdriver or sharp pointed tool.
4. Install new clutches and new retaining rings.
NOTE: If the output spindle slides toward inside of gear case, remove dead spindle spring and thread a 5/16" - 18 bolt or cap screw into end of spindle and lift up to expose retaining ring groove. Re-assemble dead spindle spring allowing no more than 1/4" projecting from end of spindle.
5. Relubricate clutches. (See lubrication)

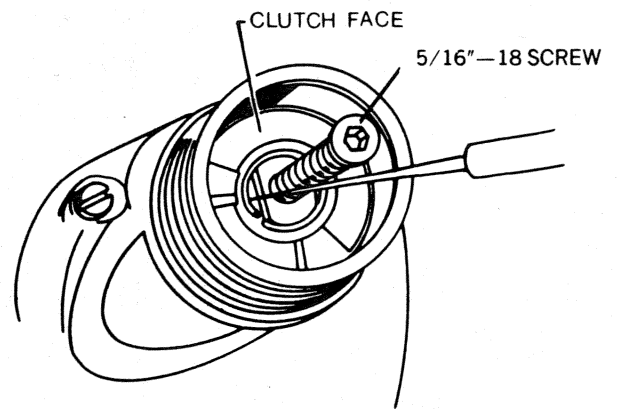

Figure 7

CHANGING CLUTCHES (Fig. 8) FOR POSITIVE CLUTCH & DRYWALL UNITS ONLY

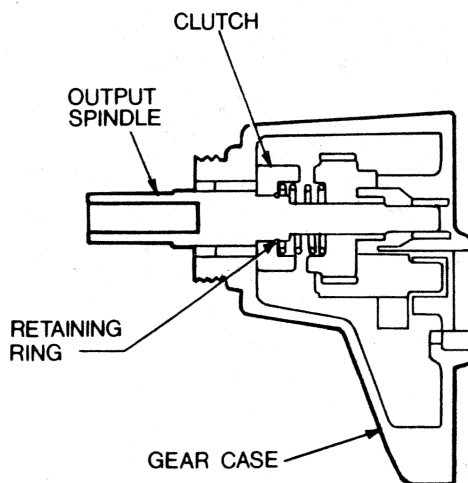

Figure 8

1. Remove three gear case screws from front and disassemble gear case.
2. Clamp output spindle in a resilient clamp.
3. Remove round clutch retaining ring with a very small screwdriver or sharp pointed tool.
4. Install a new clutch and retaining ring.
5. Relubricate clutches and gearing. (See lubrication).